



180 CCN

TOURS DE HAUTE PRÉCISION

De l'esquisse à la pièce terminée
en un temps record!

HOCHPRÄZISIONS- DREHMASCHINE

*Von der Skizze zum Fertigteil
in Rekordzeit!*

HIGH PRECISION LATHE

From the sketch to the finished
workpiece in record time!

SCHAUBLIN⁺

MACHINES SA

Longlife High Precision

www.schaublin.de



Car industry



Optical



Micro mechanic



Aeronautic-aerospace



Medical dental



Tooling



Equipment



180
CCN

Tours de haute précision
Hochpräzisions-Drehmaschine
High precision lathe

Possibilité de commander également dans ces couleurs ⇨
Es besteht die Möglichkeit folgende Farben zu bestellen ⇨
Possibility to order also in that colors ⇨



LE TOURNAGE
CCN – AUSSI
SIMPLE ET FLEXIBLE
QUE LE TOURNAGE
MANUEL!

Le tour CCN (Conventionnelle Com-
mande Numérique) allie les avantages
de la commande numérique et la
simplicité d'emploi d'un tour conven-
tionnel.

CCN-DREHEN –
SO EINFACH UND
FLEXIBEL –
WIE DAS KONVENTI-
ONELLE DREHEN!

*Die Drehmaschine CCN (konventionelle
numerische Steuerung) vereint die
Vorteile der numerischen Steuerung
und die einfache Anwendung der kon-
ventionellen Drehbank.*

CCN-TURNING –
AS SIMPLE AND
FLEXIBLE AS
CONVENTIONAL
TURNING!

The CCN (conventional control
numerical) lathe combine the
advantaged a numerical control
and the simplicity of a conventional
lathe.

FLEXIBILITY
LONGEVITY
HIGH PRECISION
SPECIALITIES

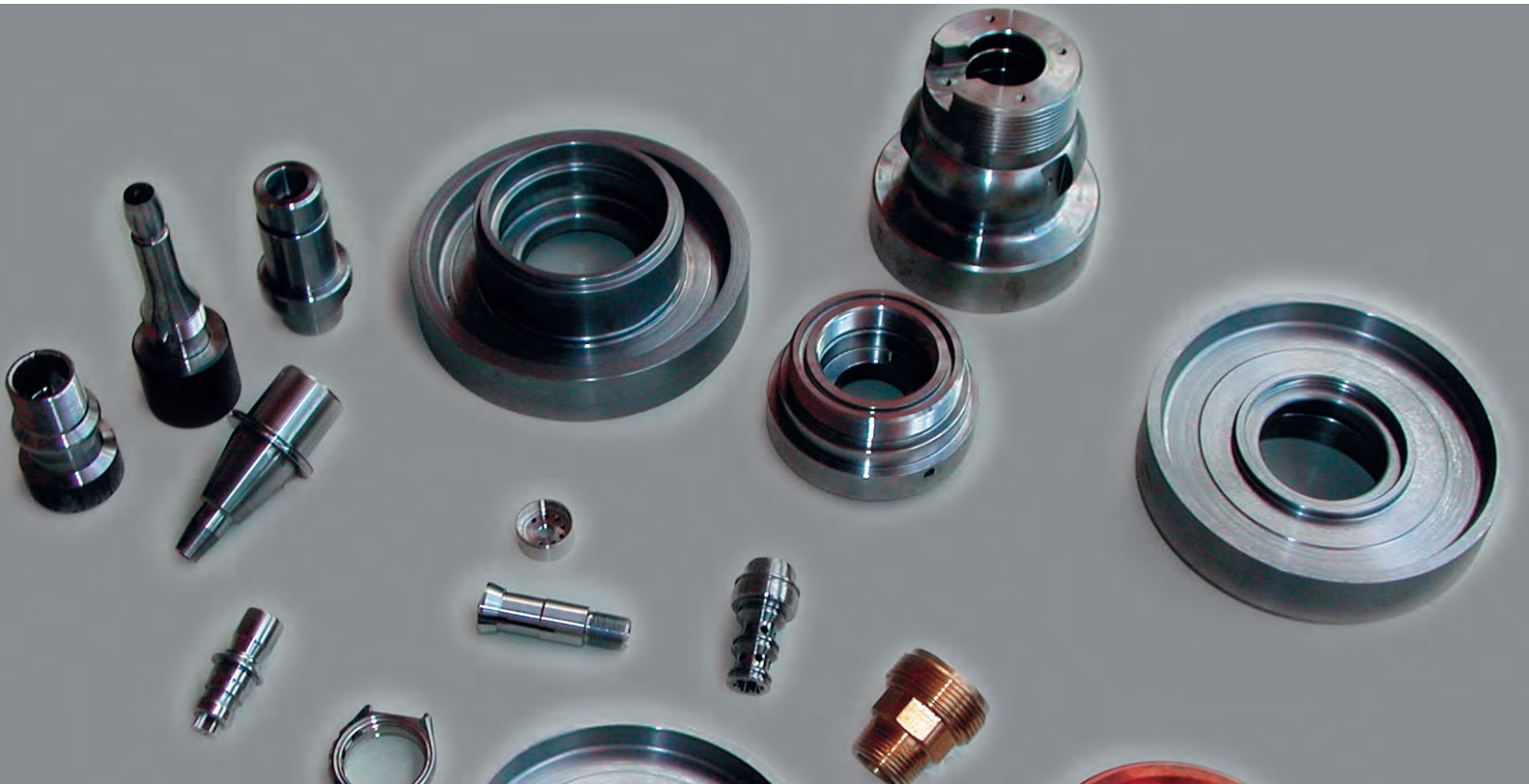

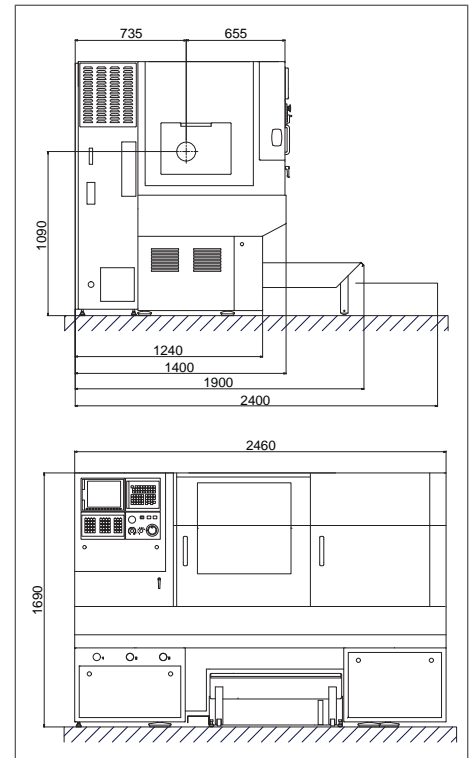
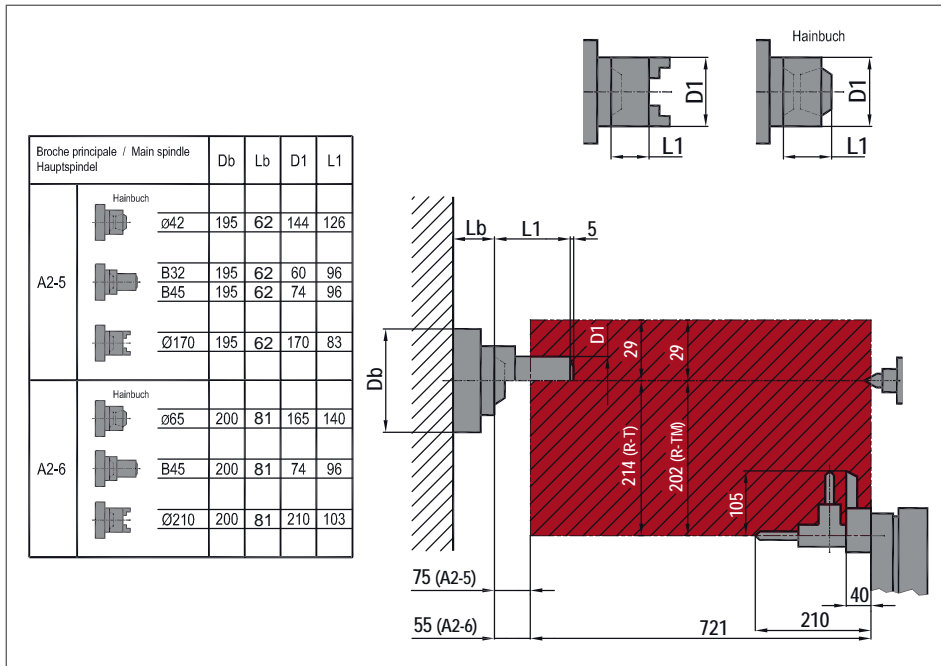

Aires de travail – Revolver outils fixes et tournants
Arbeitsbereiche – Revolver mit festen und angetriebenen Werkzeuge
Working areas – Rotating turret with fixed and driven tools

Axe C pour la version R-TM C-Achse für R-TM Version C Axis for R-TM version

Lunette fixe à charnière – Aufklappbare fixe Lünette – Hinged stationary steady
0180-70200-000

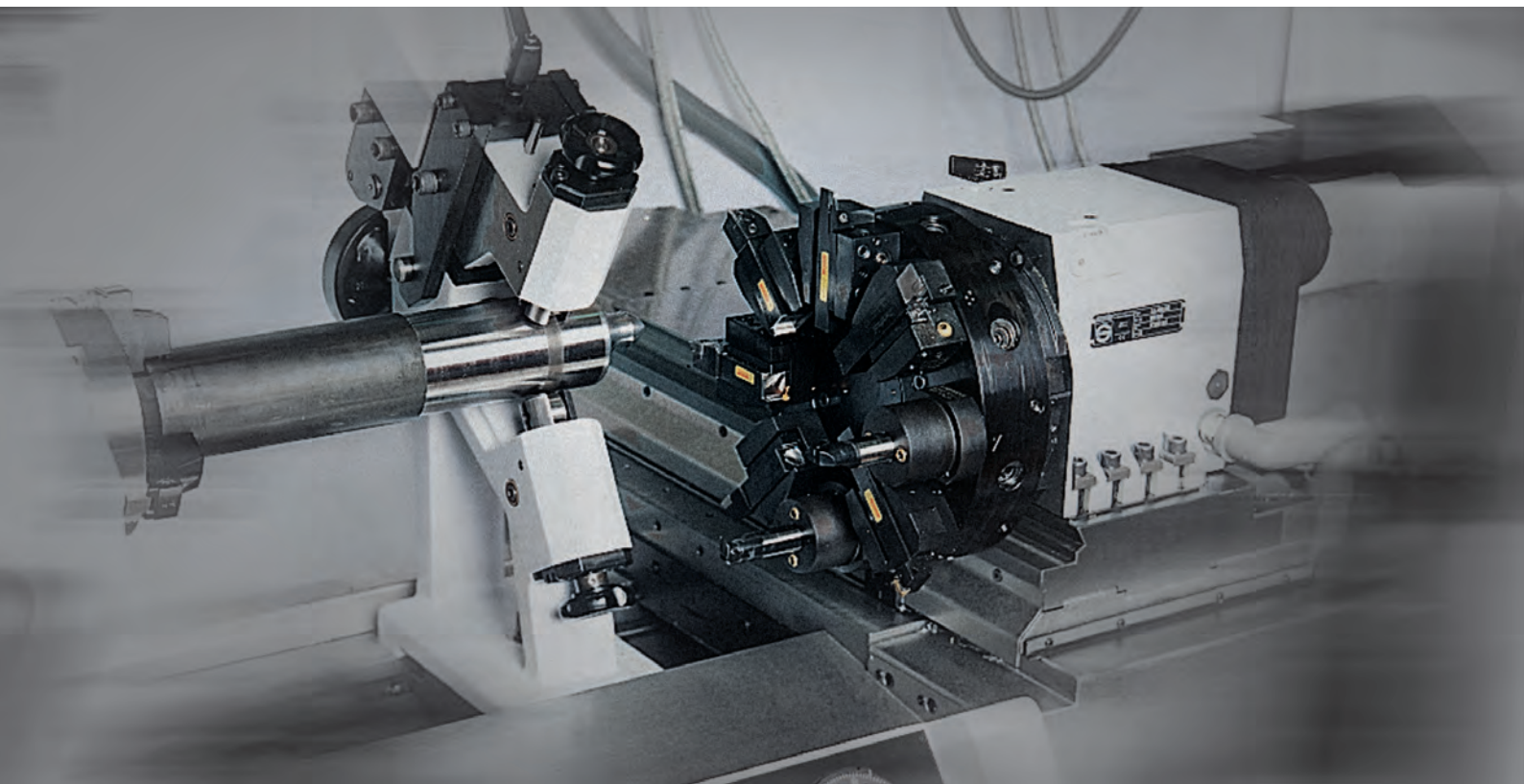

DONNÉES TECHNIQUES

Capacités	Hauteur de pointe au-dessus du banc Hauteur de pointe au-dessus du chariot Diamètre maximum de tournage Diamètre maximum de tournage conseillé Diamètre maximum admis au-dessus du chariot Longueur maximum de tournage
Poupée A2-5 / A2-6	Broche pour pinces «SCHAUBLIN» Vitesse de broche Entraînement par moteur AC, Puissance continu / intermittent Diamètre intérieur de la broche (sans clé de serrage) Passage de barre maximum en pince Passage de barre maximum en mandrin automatique
Serrage pneumatique	Force axiale de serrage réglable, force à 5 bars
Axe C	Incrément programmable Interpolation Blocage de broche pneumatique, couple de blocage à 5 bars Blocage de broche électro-magnétique, couple de blocage
Chariot croisé	Course transversale, axe X Résolution, axe X (au rayon) Entraînement par moteur AC: couple continu / intermittent Vis à billes, Ø x pas Course longitudinale, axe Z Résolution, axe Z Entraînement par moteur AC: couple continu / intermittent Vis à billes, Ø x pas
Avances	Avances de travail, axes X et Z, sans étage Avances rapides, axes X / Z
Système d'outillage: Revolver	Fixation normalisée des porte-outils Nombre de stations d'outils Nombre de stations d'outils tournants Entraînement par moteur AC: puissance continu / intermittent Entraînement par moteur AC: couple continu / intermittent Vitesse de broche, sans étage Section maximale des outils Arrosage par le centre
Contre-poupée pneumatique	Cône du fourreau de la broche Diamètre extérieur de la broche Course de la broche Force d'appui réglable
Contre-poupée à croisillons (uniquement d'appui)	Cône du fourreau de la broche Diamètre extérieur de la broche Course de la broche
Arrosage	Capacité du réservoir Débit de la pompe Pression de la pompe
Encombrement et poids	Poids net approximatif de la machine Charge au sol Hauteur de pointes au-dessus du sol Dimensions hors tout (longueur x profondeur x hauteur) en mm

TECHNISCHE HAUPTDATEN

Arbeitsbereiche	Spitzenhöhe über der Wange Spitzenhöhe über dem Schlitten Maximaler Drehdurchmesser Maximaler empfohlener Durchmesser Maximaler Durchmesser über dem Schlitten Maximaler Drehlänge
Spindelstock A2-5 / A2-6	Spindel für „SCHAUBLIN“-Spannzangen Spindeldrehzahl AC-Motorantrieb, Leistung Dauer- / Unterbrochen Spindeldurchlaß (ohne Spannschlüssel) Maximaler Stangendurchlaß mit Spannzange Maximaler Stangendurchlaß mit automatischem Futter
Pneumatische Spannvorrichtung	Regulierbar axiale Spannkraft bei 5 Bar
C-Achse	Programmierbarer Wegschritt Interpolation Druckluftbetätigte Spindelblockierung, Blockierungskraft bei 5 Bar Elektromagnetische Spindelblockierung, Blockierungskraft bei 5 Bar
Kreuzschlitten	Querweg, X-Achse Auflösung, X-Achse (Radius) AC-Motorantrieb: Dauer / Unterbrechende Leistung Kugelumlaufspindel, Ø x Steigung Längsweg, Z-Achse Auflösung, Z-Achse AC-Motorantrieb: Dauer / Unterbrechende Leistung Kugelumlaufspindel, Ø x Steigung
Vorschübe	Arbeitsvorschübe, X- und Z-Achse Eilgänge, X- / Z-Achse
Werkzeugsystem: Revolver	Normalisierte Befestigung der Werkzeughalter Anzahl der Revolverpositionen Anzahl der Revolverpositionen für angetriebene Werkzeuge AC-Motorantrieb: Leistung Dauer- / Unterbrochen AC-Motorantrieb: Dauer / Unterbrechende Leistung Spindeldrehzahl, stufenlos Größter Schaftquerschnitt der Werkzeuge Integrierte Kühlmittelzufuhr und Indexierung in beiden Richtungen
Reitstock Pneumatischer	Aufnahme Konus der Pinole Außendurchmeßer der Pinole Pinolenweg Regulierbare Abstützkraft
Reitstock mit Kreuzrad (nur um abstützen)	Aufnahme Konus der Pinole Außendurchmeßer der Pinole Pinolenweg
Kühlmittelzufuhr	Fassungsvermögen des Tanks Pumpenfördermenge Pumpenförderdruck
Abmessungen und Gewicht	Ungefähres Nettogewicht Bodenbelastung Spitzenhöhe über dem Boden Maschinenabmessungen (Länge x Tiefe x Höhe) in mm

TECHNICAL DATA

	R-T / A2-5	R-T / A2-6	R-TM / A2-5	R-TM / A2-6
Capacities				
Height of centres over bed	280 mm	280 mm	280 mm	280 mm
Height of centres over carriage	83 mm	83 mm	83 mm	83 mm
Maximum turning diameter	330 mm	330 mm	270 mm	270 mm
Recommended maximum turning diameter	250 mm	300 mm	250 mm	270 mm
Maximum swing over carriage	160 mm	160 mm	160 mm	160 mm
Maximum Turning length	655 mm	635 mm	655 mm	635 mm
Headstock A2-5 / A2-6				
Spindle for "SCHAUBLIN" collets	B32 / B45	B45	B32 / B45	B45
Spindle speed	50-5'000 min ⁻¹	50-4'000 min ⁻¹	50-5'000 min ⁻¹	50-4'000 min ⁻¹
AC motor drive, Power continuous / intermittent	15 kW / 18,5 kW	15 kW / 18,5 kW	15 kW / 18,5 kW	15 kW / 18,5 kW
Spindle throughbore (without drawbar)	51 mm	68 mm	51 mm	68 mm
Maximum throughbore with collet	24 / 36 mm	36 mm	24 / 36 mm	36 mm
Maximum throughbore with automatic chuck	43,6 mm	61 mm	43,6 mm	61 mm
Pneumatic clamping				
Adjustable axial clamping force, at 5 bars	2'700 daN	3'400 daN	2'700 daN	3'400 daN
C Axis				
Programmable increment	-	-	0,001°	0,001°
Interpolation	-	-	X - Z - C	X - Z - C
Pneumatic spindle interlock, interlock force at 5 bars	-	-	83 Nm	83 Nm
Electromagnetic spindle interlock, interlock force at 5 bars	30 Nm	30 Nm	-	-
Carriage				
Transverse stroke, X-axis	243 mm	243 mm	231 mm	231 mm
Resolution, X-axis (on radius)	0,0005 mm	0,0005 mm	0,0005 mm	0,0005 mm
AC motor drive: continuous / intermittent torque	4 / 14 N	4 / 14 N	4 / 14 N	4 / 14 N
Ball screw, Ø x pitch	32 x 5 mm	32 x 5 mm	32 x 5 mm	32 x 5 mm
Longitudinal stroke, Z-axis	721 mm	721 mm	721 mm	721 mm
Resolution, Z-axis	0,001 mm	0,001 mm	0,001 mm	0,001 mm
AC motor drive: continuous / intermittent torque	8 / 29 Nm	8 / 29 Nm	8 / 29 Nm	8 / 29 Nm
Ball screw, Ø x pitch	32 x 10 mm	32 x 10 mm	32 x 10 mm	32 x 10 mm
Feeds				
Working feeds, X- and Z-axis	0-5 m/min	0-5 m/min	0-5 m/min	0-5 m/min
Rapid feed, X- / Z-axis	8/15 m/min	8/15 m/min	8/15 m/min	8/15 m/min
Tooling system: Revolver				
Standardized fixing of toolholders	VDI 30	VDI 30	VDI 30	VDI 30
Number of tool stations	8	8	12	12
Number of rotating tool stations	-	-	6	6
AC motor drive: power continuous / intermittent	-	-	1,1 / 3,7 kW	1,1 / 3,7 kW
AC motor drive: continuous / intermittent torque	-	-	7 / 23,5 Nm	7 / 23,5 Nm
Spindle speed, stepless	-	-	30 - 5'000 min ⁻¹	30 - 5'000 min ⁻¹
Maximum tool size	20 x 20	20 x 20	20 x 20	20 x 20
Integrated cooling and indexing in both rotation direction	Oui / Ja / Yes	Oui / Ja / Yes	Oui / Ja / Yes	Oui / Ja / Yes
Tailstock operated Pneumatic				
Spindle taper	MORSE 5	MORSE 5	MORSE 5	MORSE 5
External diameter of the spindle	72 mm	72 mm	72 mm	72 mm
Spindle stroke	80 mm	80 mm	80 mm	80 mm
Adjustable pressing force	25 - 440 daN	25 - 440 daN	25 - 440 daN	25 - 440 daN
Tailstock operated with Starwheel (only to support)				
Spindle taper	MORSE 5	MORSE 5	-	-
External diameter of the spindle	72 mm	72 mm	-	-
Spindle stroke	225 mm	225 mm	-	-
Coolant supply				
Tank capacity	120 l	120 l	120 l	120 l
Pump capacity	8 l/min	8 l/min	8 l/min	8 l/min
Pump pressure	5 bar	5 bar	5 bar	5 bar
Dimensions and weight				
Approximate net weight of the machine	2'640 kg	2'640 kg	2'740 kg	2'740 kg
Load floor	385 kg/m ²	385 kg/m ²	400 kg/m ²	400 kg/m ²
High of center over floor	1'087 mm	1'087 mm	1'087 mm	1'087 mm
Overall dimensions (length x depth x height) in mm	2'460 x 1'397 x 1'683	2'460 x 1'397 x 1'683	2'460 x 1'397 x 1'683	2'460 x 1'397 x 1'683

 The 180-CCN High precision Lathes are in conformity with the European Community safety regulations (CE).

In view of the constant improvements made to our products, technical data, illustrations, dimensions and weights appearing in this catalogue are subject to change without notice.

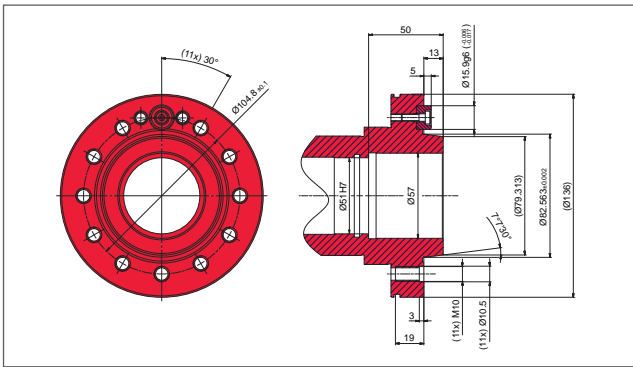

Nez de broche A2-5
Spindelnose A2-5
Spindle nose A2-5

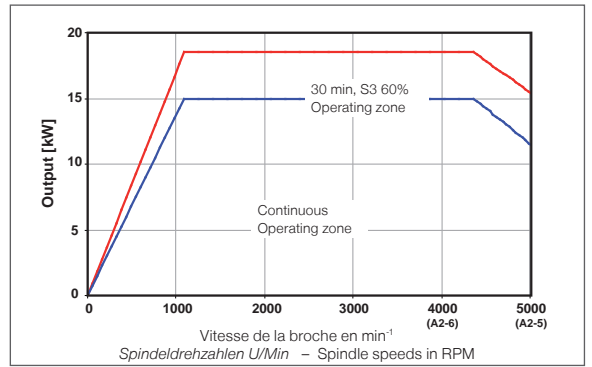

Vitesse et puissances à la broche
Spindeldrehzahlen und Leistungen
Spindle speed and power

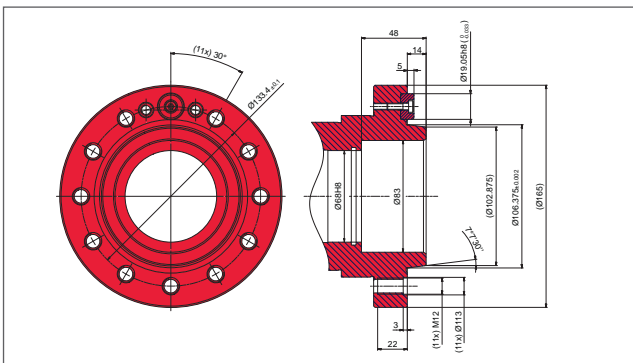

Nez de broche A2-6
Spindelnose A2-6
Spindle nose A2-6

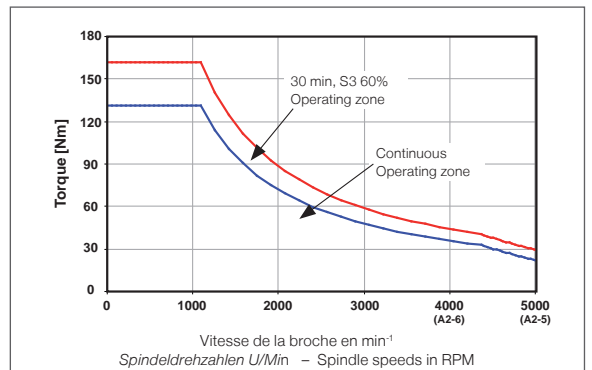

Vitesse et couples à la broche
Spindeldrehzahlen und Drehmomente
Spindle speed and torque

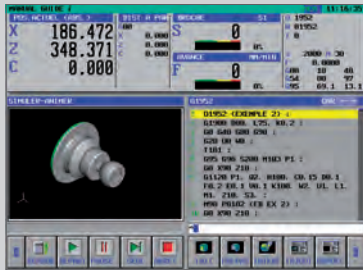

Animation graphique
Graphische Animation
Graphical animation

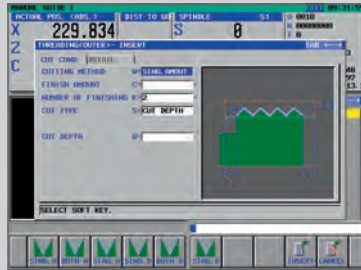

Mode Cycle: Filetage
Mode Zyklus: Gewindeschneiden
Mode Cycle: Thread cutting

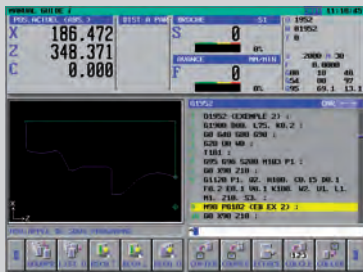
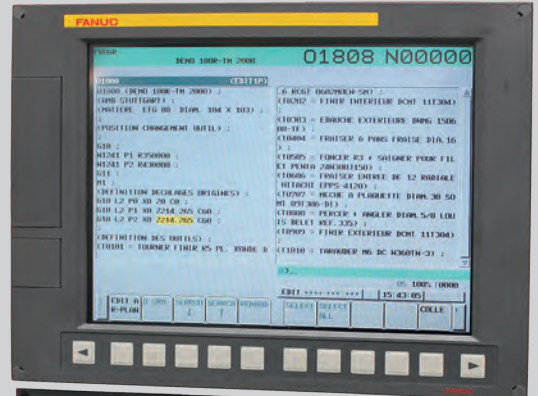

Mode Cycle: Ébauche/Finition
Mode Zyklus: Schrappen/Schlichten
Mode Cycle: Rough turning/Finishing



Mode Cycle: Perçage
Mode Zyklus: Bohren
Mode Cycle: Drilling

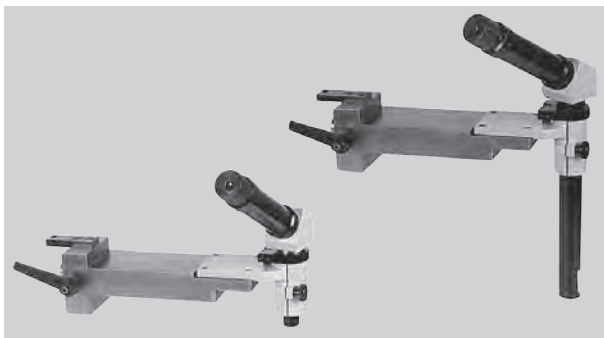

Microscope de mise à zéro des outils / de centrage des outils
Werkzeug-Nullstellungsmikroskop / Werkzeug-Zentrier-mikroskop
Tools zero setting microscope / centring microscope
0180-60000-000 / 0180-60010-000



Contre-poupée pneumatique Mo. 5
Pneumatischer Reitstock Mo. 5
Pneumatic tailstock Mo. 5
0180-65200-001



Lunette à suivre
Mitlaufende Lünette
Travelling steady
0180-70100-000

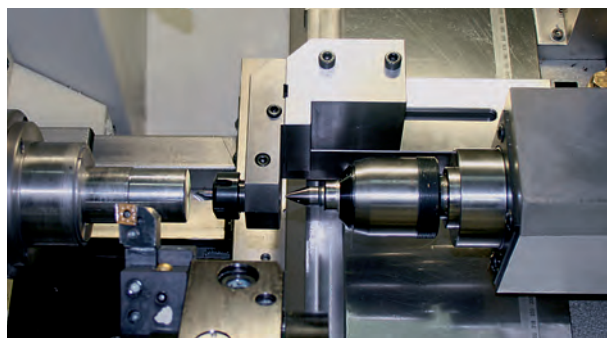

Semelle + Porte-outil de centrage arrière
Sohle + Hinterer Zentrier Stahlhalter
Saddle + Rear centering tool holder
0180-59250-000 / 0180-59240-000

NOS PRODUITS

Tournage / fraisage

UNSERE PRODUKTE

Drehen / Fräsen

OUR PRODUCTS

Turning / Milling



60-CNC / 100-CNC / 160-CNC
Centres d'usinage verticaux
Vertikale Bearbeitungszentren
Vertical Machining Centers



48V / 48V-15K / 48 APC
Centres d'usinage verticaux compact
Kompakt Vertikale Bearbeitungszentren
Compact vertical machining centers



136/142 series
Centre de tournage et de production
Hochpräzisions-Produktions-Drehcenter
High precision and production turning center



125-CCN
Tours CNC de haute précision
CNC Hochpräzisions-Drehmaschinen
High Precision CNC lathe



180-CCN
Tours CNC de haute précision
CNC Hochpräzisions-Drehmaschinen
High Precision CNC lathe



102 TM-CNC Robot
Centre de tournage et de production
Hochpräzisions-Produktions-Drehcenter
High precision and production turning center

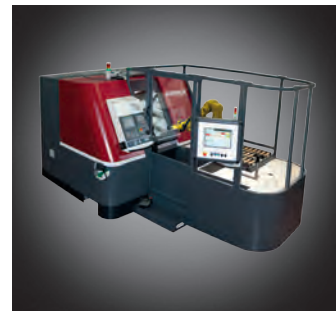

136/142 series Robot
Centre de tournage et de production
Hochpräzisions-Produktions-Drehcenter
High precision and production turning center



202 TG
Machine de production alliant tournage et rectifiage
Produktionsmaschine die Schleifen und drehen verbindet
Production machine combining turning and grinding



102 TM-CNC
Tour CNC de haute précision
CNC Hochpräzisions-Drehmaschine
High Precision CNC lathe



225 TM-CNC
Tour CNC de haute précision
CNC Hochpräzisions-Drehmaschine
High Precision CNC lathe



225 Tmi-CNC
Tour CNC de haute précision
CNC Hochpräzisions-Drehmaschine
High Precision CNC lathe



102N-VM-CF
Tour conventionnel de haute précision
Konventionelle Hochpräzisions-Drehmaschine
High Precision conventional Lathe



102N-CF / 102Mi-CF
Tours conventionnels de haute précision
Konventionelle Hochpräzisions-Drehbänke
High Precision conventional Lathes



70-CF / 70Mi-CF
Tours conventionnels de haute précision
Konventionelle Hochpräzisions-Drehbänke
High Precision conventional Lathes

Votre partenaire / Ihr Partner / Your partner